

April 2026

Cellular Vehicle-to-Everything (C-V2X)

The Standards Shaping Connected Mobility

Recent developments curated and summarized
SEPs (Standard Essential Patents) and Industry news

Published by Denne Meyer India Private Limited
Parag Thakre (pthakre@denne Meyer.com)
Prachi Gupta (pgupta@denne Meyer.com)
Himanshu Varun (hvarun@denne Meyer.com)

Subscribe now



Scan the QR code to receive this monthly report via email in your inbox.
You can also subscribe to our other insights – [Cybersecurity in Mobility](#)
and [Path to Sustainability](#) – via the same subscription center.

Preface

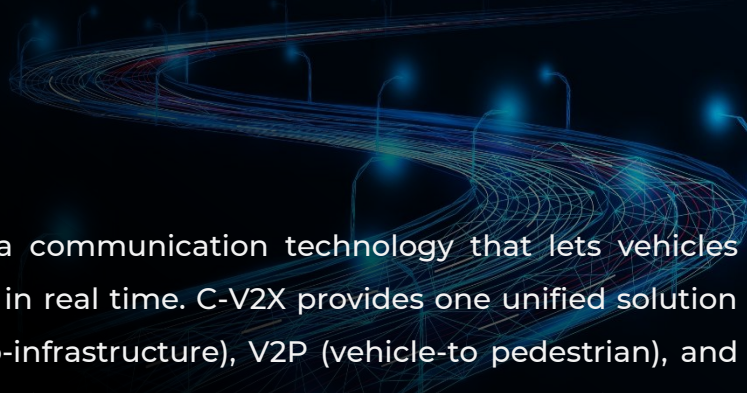

Cellular Vehicle-to-Everything (C-V2X) is a communication technology that lets vehicles share information with their surroundings in real time. C-V2X provides one unified solution for V2V (vehicle-to-vehicle), V2I (vehicle-to-infrastructure), V2P (vehicle-to pedestrian), and V2N (vehicle-to-network) by leveraging existing cellular network infrastructure. It improves road safety, reduces traffic congestion, and supports the transition toward connected and autonomous driving. C-V2X is developed and maintained by 3GPP, the global organization that creates mobile communication standards.

This monthly report highlights key developments in C-V2X standards, industry updates, and newly declared SEPs (standard essential patents). It is intended for engineers, researchers, technology leaders, IP (Intellectual Property) teams, and mobility professionals looking for a clear and simple overview of monthly C-V2X progress.

Key Insights

- ❑ Qualcomm and Toyota have the highest number of patents, with filings across major regions like the United States, China, Europe, and Japan. This shows they are strongly focused on bringing NR-V2X technology to market globally. By heavily investing in sidelink design and physical layer technology, both companies are well-placed to influence how the technology is built and licensed worldwide.
- ❑ VTect IP and NEC are among the key players concentrating their innovation on the NR-V2X sidelink architecture (TS 38.300), reflecting their strength in this area and their ability to shape how sidelink systems are deployed.
- ❑ This month's SEP data shows that most patent activity is concentrated in the sidelink architecture standard (TS 38.300), followed by key physical layer standards (TS 38.214 and TS 38.213). This tells us that current innovation is focused on the core communication design needed to deliver reliable, low-latency performance for safety-critical V2X applications, with strong participation from leading industry players.
- ❑ Ettifos demonstrated the use of V2X for toll collection in partnership with Audi and Kapsch, showing that Vehicle to Infrastructure (V2I) communication is moving closer to real commercial deployment in everyday mobility services like tolling, payments, and roadside services.
- ❑ Another emerging use case is mining, where Cohda Wireless is deploying C-V2X technology at the Oyu Tolgoi mine in Mongolia. In environments where GPS is weak or unavailable, the technology enables accurate real-time tracking, which can help prevent collisions and improve emergency response.



A street scene with several cars driving. The road has blue markings with white arrows. Above the cars, there are blue wireless signal symbols (three curved lines) and blue arcs connecting them, representing C-V2X communication. The scene is framed by green trees on both sides.

C-V2X SEP Landscape

C-V2X

C-V2X (Cellular Vehicle-to-Everything) is a technology that lets vehicles share information with other vehicles, pedestrians, and roadside systems in real time. It helps prevent accidents, reduces traffic jams, supports efficient driving, and prepares the way for connected and autonomous vehicles.

C-V2X is standardized by 3GPP, the global organization that develops mobile communication standards for 4G, 5G and future technologies. 3GPP's work is carried out through three groups: **(1). RAN (Radio Access Network), (2). SA (System and Services), and (3). CT (Core Network and Terminals)**. These groups produce the Technical Specifications (TS) that define how C-V2X operates across different layers.

Which technologies does C-V2X include?

C-V2X evolves through major 3GPP releases:

- **4G LTE-V2X** (Release 14/15, 2017-2018): Initial version of C-V2X
- **5G New Radio (NR) -V2X** (Release 16/17/18, 2020-2024): Enhanced reliability, lower latency
- **5G-Advanced NR V2X** (Release 19, 2025): Latest phase with ongoing improvements

3GPP Release 19 continues to strengthen 5G-V2X with enhancements in sidelink communication, network efficiency, and system-level improvements to support advanced cooperative driving.

5G-Advanced NR V2X Sidelink

(The TS 38 series was introduced in Release 15 and has progressively evolved through Release 19.)

- TS 38.211: NR sidelink physical channels & modulation
- TS 38.212: Multiplexing and channel coding for sidelink
- TS 38.213: Physical layer (PHY) procedures for control
- TS 38.214: Physical layer (PHY) procedures for data
- TS 38.321: Medium Access Control (MAC) protocol specification
- TS 38.331: Radio Resource Control (RRC); Protocol specification
- TS 38.300: Overall NR/NG-RAN with sidelink architecture

5G-Advanced NR V2X Architecture (Service & System Layer)

(The TS 22 series began in Release 14, while TS 23 started in Release 16 and evolved through Release 19.)

- TS 23.287: Architecture enhancements for 5G System (5GS) to support Vehicle-to-Everything (V2X) services
- TS 22.186: 5G; Service requirements for enhanced V2X scenarios
- TS 22.185: LTE; Service requirements for V2X services

Top Assignees: Monthly (Mar 2026) patent activity related to C-V2X standard and Geographic distribution

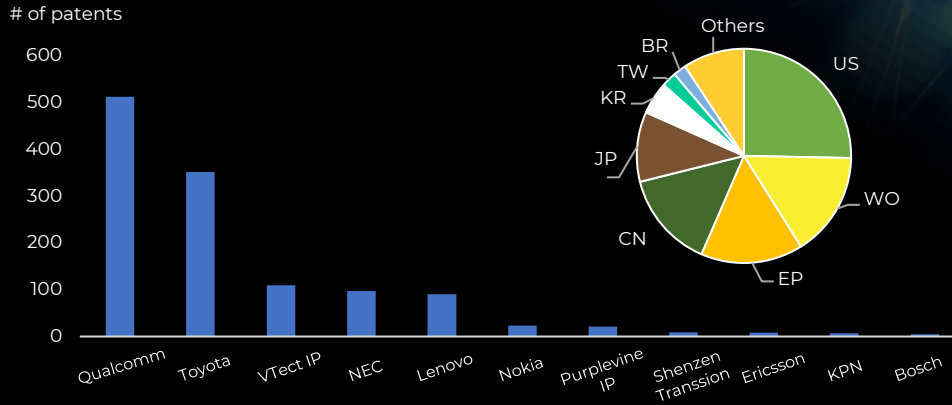

As per March 2026 data

- Qualcomm and Toyota show strong activity across sidelink architecture and key PHY-layer TS, highlighting broad involvement in NR-V2X implementation-critical technologies. Their balanced coverage across control, data, and channel modulation points to an end-to-end sidelink strategy rather than a narrow technical focus.
- VTect IP and NEC show a clear concentration in TS 38.300 (sidelink architecture), highlighting a focus on core system design and sidelink framework definition. This positioning is critical for long-term influence over how NR-V2X sidelink communication is structured and deployed.
- Patent filings remain highly concentrated in WO, CN, US, EP and JP, indicating that assignees continue to prioritize global protection alongside coverage in the most commercially relevant markets.
- TS 38.300 leads this month's SEP activity, followed by TS 38.214 and TS 38.213, confirming continued focus on sidelink architecture and PHY data and control. This focus reflects industry priorities around reliability and low-latency performance for safety-critical V2X use cases.

Number of declarations per Technical Specifications (TS)

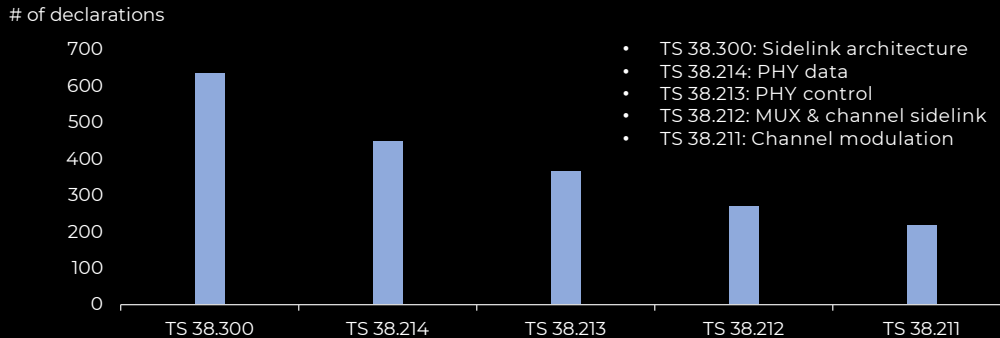



PATENT

The editor's shortlist

Declared Patents Of The Month



SEPs of the month

Declared in March 2026

Sampled and curated by our analyst, based on Assignee and Technical Specification (TS)

- [US2024214854A1](#) - Techniques for transmitting an event-triggered non-serving cell beam report
Assignee: [Qualcomm Inc](#)
- [WO2022124264A1](#) - Targeted Multicast Broadcast Services (MBS) notification signaling
Assignee: [Toyota Motor Co Ltd](#)
- [CN108029117B](#) - Method and apparatus for resource allocation
Assignee: [VTect IP Inc.](#)
- [WO2024000588A1](#) - Method, device and computer storage medium of communication
Assignee: [NEC Corp](#)
- [WO2022067708A1](#) - Method and apparatus for user equipment (UE) discovery
Assignee: [Lenovo Beijing Co Ltd](#)
- [GB2643053A](#) - UE triggered measurement reporting
Assignee: [Nokia Technology Oy](#)
- [US12471138B2](#) - Channel access method, user equipment, and base station
Assignee: [Purplevine Innovation Company Ltd](#)
- [CN121312242A](#) - Processing method, communication device and storage medium
Assignee: [Shanghai Transsion Information Technology Ltd](#)
- [US11792840B2](#) - Reliable low latency communication over shared resources
Assignee: [Koninklijke KPN NV](#)
- [EP4322694A1](#) - Methods, apparatuses and system for transmitting a request to a terminal device
Assignee: [Robert Bosch GMBH](#)



◀ US2024214854A1

Techniques for transmitting an event-triggered non-serving cell beam report

Declared in TS 38.214 within the C-V2X standard.

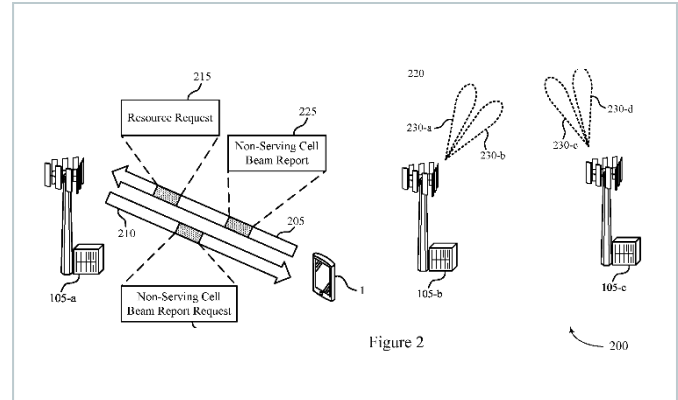

Figure 2

The patent fixes a problem where phones can share signal quality information about nearby cell towers only after the network specifically asks for it. This back-and-forth takes time and creates extra network messages. The invention lets the phone monitor signal beams from nearby, non-connected towers on its own and decide when a report is needed. If the phone notices that signal quality drops or changes a lot, it asks the network for permission or resources to send a report. Once the network allows it, the phone sends detailed signal quality information. Depending on how the system is set up, this can be sent in different ways. By letting the phone trigger reports based on real-time signal conditions, the system becomes faster and more efficient. Overall, this improves mobility, reduces delays, and helps the network manage multiple transmission points better.





◀ WO2022124264A1

Targeted Multicast Broadcast Services (MBS) notification signaling

Declared in TS 38.212, and TS 38.300 within the C-V2X standard.

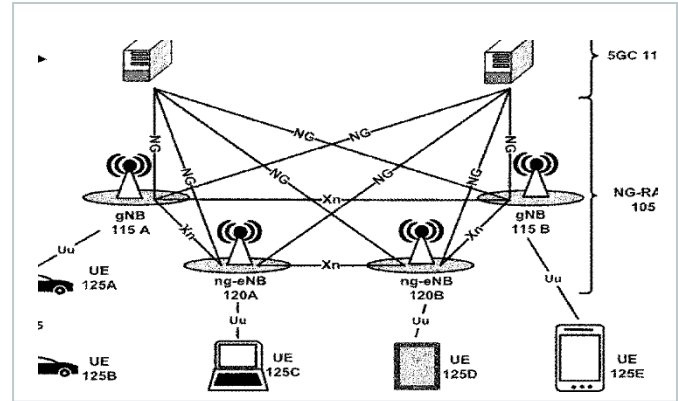

The patent looks at a problem where phones and devices waste battery power by waking up for broadcast messages they do not even need. Today, when a broadcast or multicast service sends a paging message, all nearby devices are alerted, even if most of them are not using that service. This forces many devices to wake up and process signals unnecessarily. To fix this, the invention uses smarter paging messages that clearly show which broadcast service they belong to. A device checks the message and responds only if it is actually interested in that service. If not, it simply ignores the message and stays in low power mode. The system also supports multiple broadcast services at the same time by using different identifiers. Overall, this approach saves battery life, reduces unnecessary network activity, and ensures that only the right devices are notified.





◀ CN108029117B

Method and apparatus for resource allocation

Declared in TS 38.212, and TS 38.214 within the C-V2X standard.

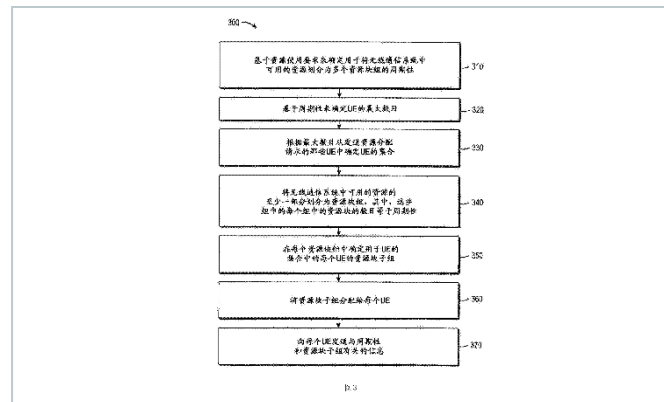

This patent addresses how to assign wireless resources when devices using unlicensed spectrum must use a minimum amount of bandwidth to work properly. Current resource allocation methods do not account for these minimum usage rules, which can lead to devices getting too little bandwidth and not functioning as intended. The invention first identifies which devices are requesting resources and checks both the available bandwidth and the required usage conditions. It then assigns resources in a way that meets these requirements, such as grouping resources, allocating fixed sets of resource blocks, or handling the middle and edge parts of the bandwidth differently. In some cases, multiple devices can safely share the same resource blocks. Each device receives clear instructions on which resources it can use and when to use them, ensuring more reliable operation.





◀ WO2024000588A1

Method, device and computer storage medium of communication

Declared in TS 38.300 within the C-V2X standard.

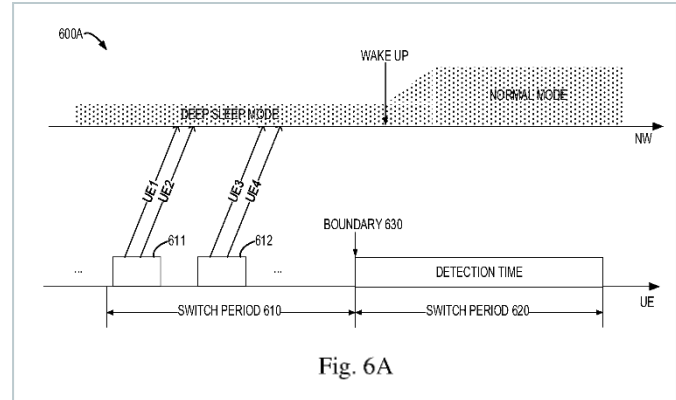

The patent is about saving energy in mobile networks while still ensuring that users can connect when needed. Some network cells enter a deep sleep mode to save power, but waking them up quickly and efficiently is not well handled today. This invention allows a user device to know exactly how and when it should help wake up a sleeping cell. Based on this information, the device can either send a wake-up signal or check whether the cell has already partially woken up. The patent also explains timing rules and retry steps to confirm that the cell is active again. By clearly defining how wake-up signals work, the system avoids unnecessary messages and delays. Overall, this approach helps networks save energy without affecting reliable service for users.



◀ WO2022067708A1

Method and apparatus for user equipment (UE) discovery

Declared in TS 38.300 within the C-V2X standard.

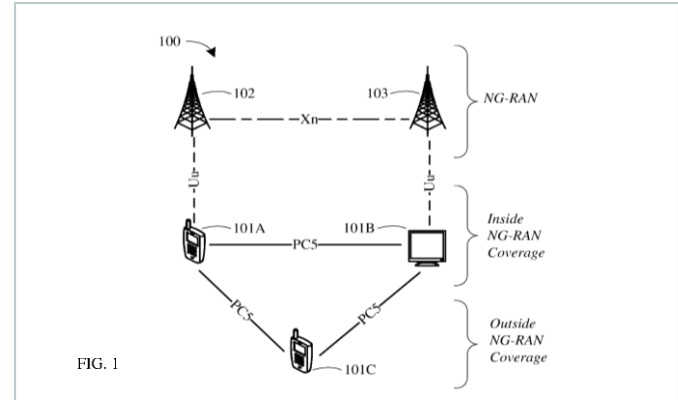

The patent deals with how devices find each other when they communicate directly, without going through the mobile network. Today, there is no clear or efficient way to send and handle these “discovery” messages, and devices cannot easily tell how close or relevant another device is. The invention introduces a clear process for sending discovery messages, starting from the software layer and passing them through dedicated communication channels so they can be broadcast properly. Devices can clearly mark messages as discovery messages, such as announcements from relay devices or requests asking for nearby help. The solution works for different relay setups, including device-to-device and device-to-network communication. It also adds location and distance information so devices can identify nearby or useful peers.





◀ **GB2643053A**

UE triggered measurement reporting

Declared in **TS 38.213**, **TS 38.214** and **TS 38.300** within the **C-V2X** standard.

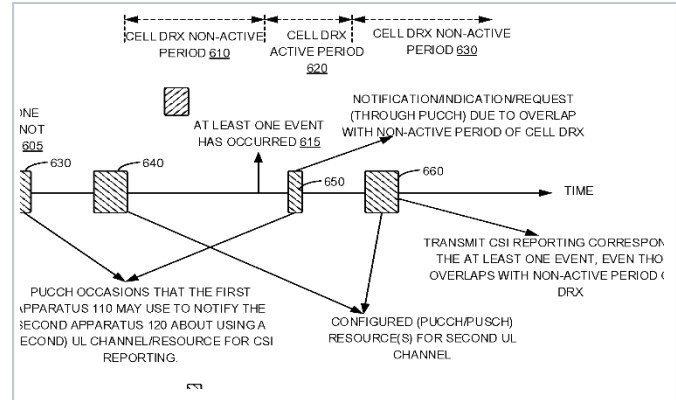

The patent deals with a problem where a device cannot send important update messages to the network because the required uplink resources are not available at that moment. This can happen when the device is in a sleep cycle, busy receiving data, using the uplink for higher priority tasks, or when the assigned resource is cancelled. As a result, important reports used for signal quality and beam management may be delayed or lost. To solve this, the invention allows the device to first check if it has the right resources before trying to send such messages. If the resources are not available, the device follows clear rules set by the network, such as waiting and sending the message later, using a different resource, temporarily holding the message, or dropping it after a certain time. Because these rules are defined in advance, both the device and the network behave in a predictable way. Ensuring reliable report delivery without wasting network resources.



◀ **US12471138B2**

Channel access method, user equipment, and base station

Declared in TS 38.212, TS 38.213, and TS 38.214 within the C-V2X standard.

Company name: Purplevine Innovation Company Ltd

Inventors: Chien Chun Che

Priority date: 21 Dec 2020

Publication date: 11 Nov 2025

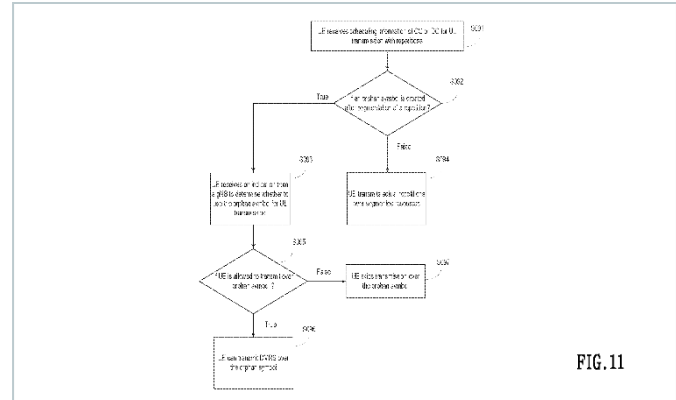

FIG. 11

This patent improves reliable and low-latency wireless communication in unlicensed spectrum (2.4GHz, 5GHz) for industrial IoT applications. In existing approaches, devices rely too heavily on the base station (BS) and must wait for signals from the BS before sending data, which reduces flexibility, increases delay, and raises power consumption. The invention allows the device to start using the wireless channel on its own by following a semi-fixed access method configured during the initial connection process. The BS provides configuration details and frame timing information, and the device decides when to access the channel based on this information and its detection of downlink signals. Once the device confirms that the channel is free, it begins using the channel and transmits uplink data within the allowed parts of the frame.



◀ **CN121312242A**

Processing method, communication device and storage medium

Declared in **TS 38.213** within the **C-V2X** standard.

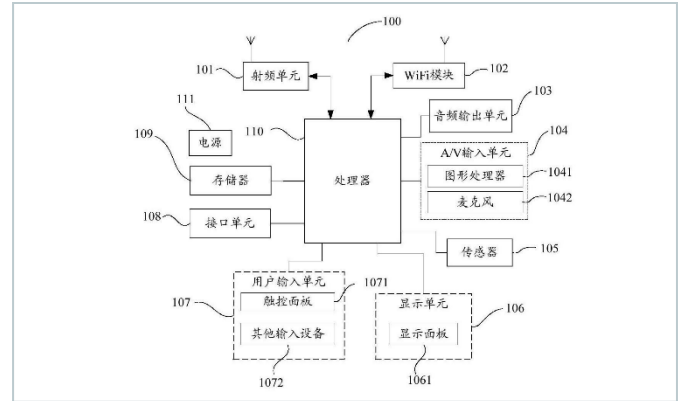

The patent solves a problem that happens when a mobile device first tries to connect to the network and the network does not know what kind of device it is. This is especially an issue for newer lightweight devices, which work more slowly. Because the network does not know this, it may schedule the connection too quickly, causing the device to miss the timing and fail to send data properly, especially when using wider bandwidth. To fix this, the patent allows the device to change how it connects if certain conditions are met. Instead of using a faster but less flexible connection method, the device switches to a slightly longer method and sends early information about its device type. This helps the network understand the device's limits and plan the connection better.





◀ US11792840B2

Reliable low latency communication over shared resources

Declared in **TS 38.212**, **TS 38.213**, and **TS 38.214** within the **C-V2X standard**.

Company name Koninklijke KPN NV

Inventors Das Kallol,
Jorguseski Ljupco

Priority date 24 Jul 2018

Publication date 17 Oct 2023

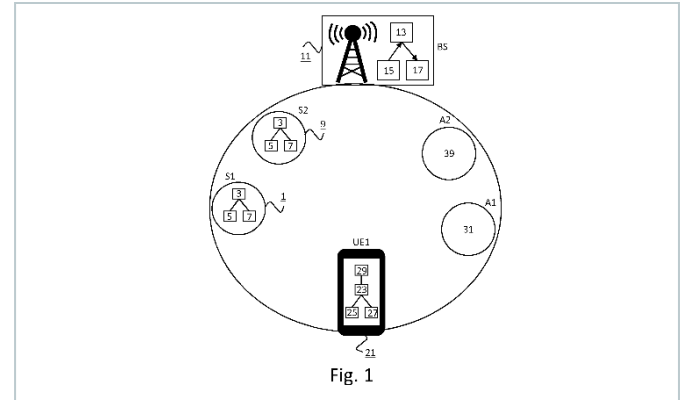

This patent addresses the challenge of delivering very fast and highly reliable wireless communication for industrial applications, especially when devices need to talk to each other without always having dedicated network capacity. Current systems face problems because adding backups to improve reliability often increases delay, and sharing radio resources can lead to interference and data collisions, which existing 5G standards do not fully handle. The invention solves this by first sending a brief alert signal on a specific frequency to inform nearby devices that an urgent and critical data transmission is coming. The actual data is then sent in the next time slot, with multiple copies or parts of the data transmitted at the same time using different frequencies. Devices that detect the alert signal avoid those frequencies, which reduces interference. As a result, the data is delivered more reliably without adding extra delay.





◀ EP4322694A1

Methods, apparatuses and system for transmitting a request to a terminal device

Declared in TS 38.300 within the C-V2X standard.

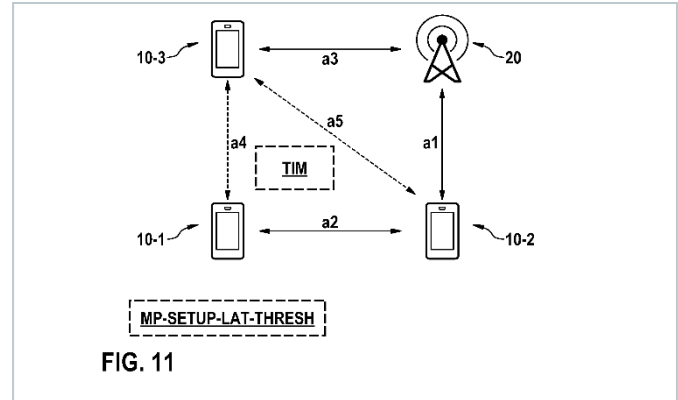

The patent focuses on a situation where a device cannot connect directly to the network and instead uses another nearby device as a relay. If only one relay device is used, the connection can become slow or unstable. To improve this, the invention allows the main device to use multiple relay devices at the same time. The device first sends a request asking to activate this multi-relay setup and receives confirmation. Once enabled, the device can send and receive data through several relay devices together, which makes the connection more stable and faster. The patent also explains how extra relay devices are found and chosen, and how they work together with the network, including base stations. This works both for direct device-to-device relays and for relays connected through the network.



The editor's shortlist

News of the month

V2X Based Collision Prevention

Renault V2X trial in Bordeaux puts connected mobility story in focus

Renault and Eye-Net Mobile (subsidiary of Foresight) have tested a new V2X-based collision prevention technology in Bordeaux's public transport system. The technology enables vehicles and buses to communicate with each other to avoid accidents and demonstrated strong performance even when many users were connected simultaneously. The trial included integration with apps used by bus operators and cyclists, showing that the solution works in real urban environments. Renault is now in discussions to commercialize the technology, which could strengthen its position in the smart and safe urban transport market. The project aligns with Renault's focus on safer, more connected vehicles, and if successful, it could give Renault an advantage over competitors such as Volkswagen and Ford in connected mobility.

Source

<https://simplywall.st/>



V2X Tolling Solution

Ettifos successfully showcases interoperable V2X tolling with Audi and Kapsch

Ettifos demonstrated its V2X tolling technology in North Carolina with Audi and Kapsch, showing that vehicles can communicate directly with tolling stations for instant payment. The tests showed that Ettifos' V2X-AIR onboard unit worked smoothly with Kapsch's roadside units, whether installed in Audi vehicles or used as a dashboard add-on for other vehicles. The technology enables automatic toll payments as vehicles pass through toll zones and provides real-time payment confirmations to drivers. Both factory-installed and aftermarket devices processed tolling and safety messages quickly and accurately, confirming the system's reliability. Ettifos' V2X-AIR unit meets U.S. federal requirements for infrastructure projects, making it suitable for wide adoption. The technology supports tolling and road safety functions and can be deployed in both new and existing vehicles.

Source

<https://www.ettifos.com/>

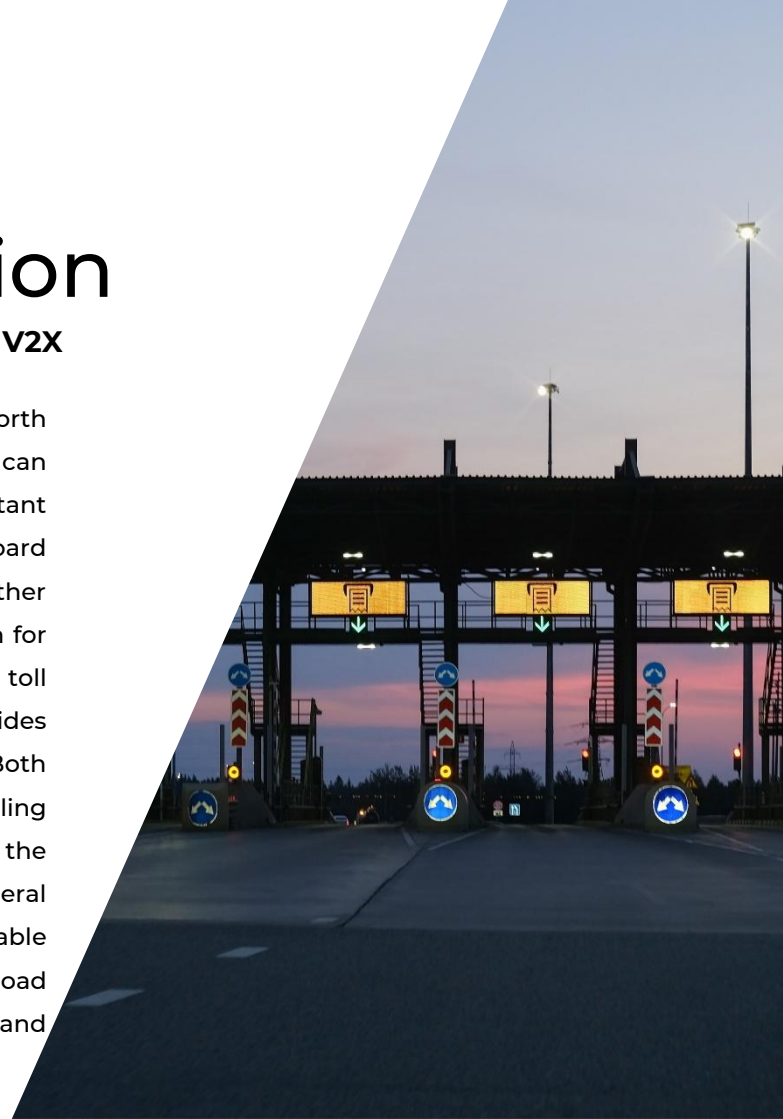

V2X Solution For Mines

Cohda wireless driving smart city solution at Oyu Tolgoi mine

Cohda Wireless is using its advanced vehicle positioning technology at the Oyu Tolgoi copper and gold mine in Mongolia to improve safety. Its V2X-Locate system can track vehicles and people underground with sub-meter accuracy, even in areas where satellite signals are unavailable. This technology, originally designed for city environments with poor GPS coverage, uses specialized wireless signals and algorithms to pinpoint locations. Over 200 mining vehicles and 2,000 workers will use this system, with vehicles and workers' cap lamps fitted to communicate their positions in real time. The system warns operators of potential collisions and helps manage traffic and emergencies in the mine. Cohda's solution is more accurate and integrated than the usual mix of different safety systems used in mines. The goal is to create a universal standard for connected vehicle safety across brands and systems.

Source

<https://cohdawireless.com/>



Strategic Partnership

Ettifos and SUM partner to advance transportation logistics automation with 5G-V2X

Ettifos and Smart yoUr Mobility (SUM) have signed a Memorandum of Understanding (MoU) to work together on developing remote and autonomous driving solutions using advanced 5G-V2X. They aim to speed up the automation of transport in complex industrial areas such as ports, mega hubs, and large factories. Ettifos will provide expertise in secure, high-speed vehicle communication networks, while SUM will contribute its autonomous driving systems and integration capabilities. The focus is on making data exchange between vehicles and control centers cheaper and more reliable. The partners will test and develop their solutions at Seoul National University's Future Mobility Technology Center, combining SUM's autonomous vehicles with Ettifos' communication technology in real-world scenarios.

Source

<https://www.ettifos.com/>



We are now in India

Your global full-service IP partner

With 60+ years of experience and over 20 offices worldwide, Dennemeyer Group is committed to being the first choice partner for the protection and management of Intellectual Property (IP) rights globally.

Our India office is your gateway to the world of IP, offering a single point of contact and full-service IP management solutions to support you throughout your IP life cycle.



IP consulting



IP law firm services



IP maintenance services



IP management software



Octimine patent analysis software

By the numbers



Founded in
1962



180
jurisdictions
covered worldwide



~2 Million
patents maintained



~1 Million
trademarks managed



>60
years
of experience in IP



>20
global offices



>900
employees and
associates

Global presence

Abu Dhabi, UAE
Beijing, CN
Bengaluru, IN
Brasov, RO
Chicago, USA
Dubai, UAE
Howald, LU
Johannesburg, ZA
Manila, PH
Melbourne, AU
Munich, DE
Paris, FR

Rio de Janeiro, BR
Rome, IT
Singapore, SG
Stockport, UK
Taipei, TW
Tokyo, JP
Turin, IT
Warsaw, PL
Woking, UK
Zagreb, HR
Zug, CH

Talk to us now

Find out how we can support you
in these services and more.

- International Patent and Trademark Renewals
- International Patent and Trademark Filings
- European Patent Validation
- PCT Nationalization
- Recordals
- DIAMS IP Management Software
- Patent Search & Analysis



Visit us

at www.dennemeyer.com to find out more about us.

 Denne Meyer India Private Limited
Bengaluru
info-india@dennemeyer.com

 North & East India
+91 9818599822

South & West India
+91 88266 88838